

SHOCK ABSORBER AND FRONT SHOCK MOUNT

GENERAL

The purpose of this bulletin is to announce the release of a **new** shock absorber kit for all 1995-2000 S1, S1W, M2, S2/S2T, S3/S3T, and X1 Model Buell motorcycles and to provide installation and adjustment instructions. Buell Motorcycle Company has developed this kit as an upgrade to the shock absorbers currently in use.

VEHICLES INVOLVED

All domestic and international 1995-2000 S1, S1W, M2, S2/S2T, S3/S3T, and X1 Model Buell motorcycles. These shock absorber service kits may be used on motorcycles that:

- Have not been involved in either recall campaign and need to service the shock.
- Have been involved in either recall campaign, have had the original recall kit installed and need to service the shock.

If the same type shock absorber is being replaced, order only the shock absorber and not the service kit.

If the motorcycle requires a recall service, see the appropriate service bulletin for instructions and credit procedure.

DEALER ACTION

Follow the instructions provided to install the kit. See below for list of Kit Contents:

The shock absorber kit (See below for correct part number) consists of:

- **New** Shock Absorber
- Clamp (for shock reservoir to bracket)
- Clamp (for shock reservoir to oil return line)
- Washer 1/4 in. (for reservoir clamp)
- (2) Locknuts, Nylon (shock mounting)
- Reservoir Mount Block
- **New** Front Shock Mount
- (2) Front Shock Mount Bolts
- (2) Locknuts, metal (for front shock mount)
- (3) Washers (for front shock mount)
- Screw (for voltage regulator bracket)
- **New** X1 Chin Fairing Bracket (X1 only)
- Wellnut (X1 only)
- Star Washer, 3/8 in. (1997 M2, S3/S3T only - front shock mount)
- Star Washer 1/4 in. (1997 M2, S3/S3T only - voltage regulator bracket)
- (2) Exhaust Port Gaskets
- **New** Header Tiebar Spacer

- Customer Instructions for Shock Replacement and Adjustment

The shock absorber kit is different depending on the motorcycle model. See below for the correct kit part numbers:

S1/S1W/M2/X1: Part No. K1400.C

S2/S2T/1999-2000 S3/S3T: Part No. K1400.8

1997-1998 S3/S3T: Part No. K1400.E

REMOVAL

NOTE

- Perform the following procedures according to the guidelines given in the service manual for the model being serviced.
- For instructions on installing these shocks on motorcycles that did not have the original 0817 recall service performed, see Bulletin B-024A for instructions and proper credit procedure.

All Models

1. Lift rear wheel off ground using REAR WHEEL SUPPORT STAND (Part No. B-41174). Secure front wheel of motorcycle in a suitable lift.

⚠ WARNING

To protect against shock and accidental start-up of vehicle, disconnect the negative battery cable before proceeding. Inadequate safety precautions could result in death or serious injury.

2. Disconnect negative battery cable.
3. **X1 Models Only:** Remove chin fairing. See Section 2 of X1 Service Manual for procedure.
4. See Figure 1. Place a suitable jack under the swing arm mount block and raise until crankcase is supported by jack.

NOTE

Steps 5-6 do not apply to M2 Cyclone models with original equipment shocks which did not have a remote reservoir.

5. See Figure 2. Use a flex socket and extension to remove locknut and washer from front reservoir clamp. Discard clamp, locknut and washer.
6. See Figure 2. Loosen rear reservoir clamp. Slide reservoir and mount block out of clamp. Remove and discard clamp and mount block.

ROUTING	SERVICE MANAGER	SALES MANAGER	PARTS MANAGER	LEAD TECHNICIAN	TECHNICIAN NO. 1	TECHNICIAN NO. 2	TECHNICIAN NO. 3	TECHNICIAN NO. 4	RETURN THIS TO:
INITIAL HERE									

NOTE

On motorcycles equipped with the Shock Reinforcement Package (SRP), there is no need to disassemble the SRP during removal as the shock and SRP are removed as an assembly.

7. Remove allen screw and locknut (metric) from front shock and front shock mount. Discard locknut.
8. Remove allen screw, locknut (metric) and washers (if present) from rear shock and swingarm while supporting shock absorber. Discard locknut. On aluminum swingarms only: retain washers for re-use.
9. Remove and discard shock absorber assembly.
10. **All Models Except S1/S1W/S2/S2T:** Remove two screws, washers, star washer (present on 1997 M2, S3/S3T) and voltage regulator from bracket. Discard star washer.
11. **All Models Except S1/S1W/S2/S2T:** Remove small button head screw and metal locknut (if present) that secures voltage regulator bracket to front shock mount. Leave bracket in place. Discard screw and metal locknut.

NOTE

Model Year 1995-1999 motorcycles have unthreaded front shock mounts that require the use of washers and metal locknuts to secure the front shock mount to the crankcase. Model Year 2000 front shock mounts were threaded and no locknuts were used. The new front shock mount is not threaded and will require the use of the new mounting hardware which includes washers and metal locknuts.

12. Remove top and bottom front shock mount bolts, washers, star washer (present on 1997 M2,S3/S3T) and locknuts. Remove and discard front shock mount. Discard bolts, locknuts, washers and star washer. NOTE: If interference is encountered removing bolt from shock mount, it may be necessary to loosen the header/muffler to remove bolt. See appropriate Service Manual, Section 2 for instructions.

INSTALLATION

IMPORTANT NOTE

The new front shock mount **MUST** be used with the new shock absorber. The new shock is 1.77 in. (45 mm) shorter than the previous shocks and requires the new front mount to align and install properly.

1. See Figure 2. Install **new** front shock mount to crankcase with two **new** front shock mount bolts, washers, star washer (on 1997 M2, S3/S3T models only) and metal locknuts. Tighten bolts to 30-33 ft-lbs (41-45 Nm). NOTE: Top bolt goes in from the left side, bottom bolt goes in from right side. Bottom bolt does not use washer under bolt head. Star washer (only used on 1997 M2, S3/S3T models) goes on bottom bolt under the washer on the nut side. If exhaust was loosened during front shock mount removal, replace exhaust gaskets and reinstall exhaust. See appropriate Service Manual, Section 2 for instructions.
2. **All Models Except S1/ S1W/S2/S2T:** Apply LOCTITE THREADLOCKER 243 (Blue) to threads of **new** button head fastener. Fasten voltage regulator bracket to front shock mount with **new** small button head fastener. Tighten fastener to 5-6 ft-lbs (7-8 Nm).

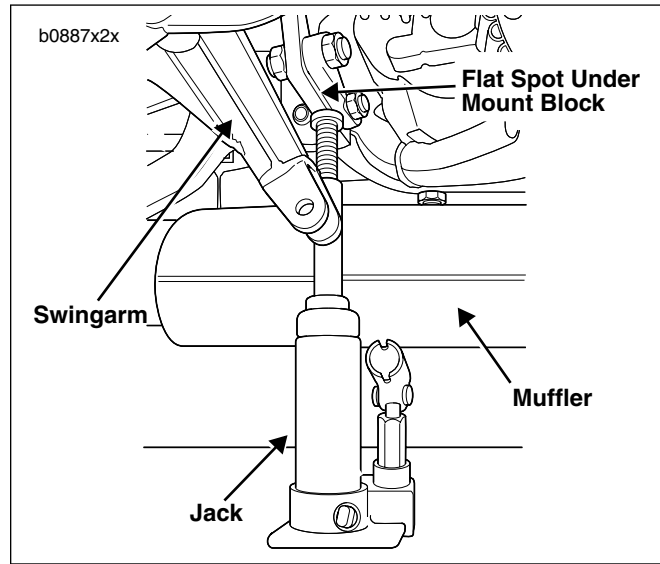

Figure 1. Jack Location on Mount Block (Shock Removed for Clarity)

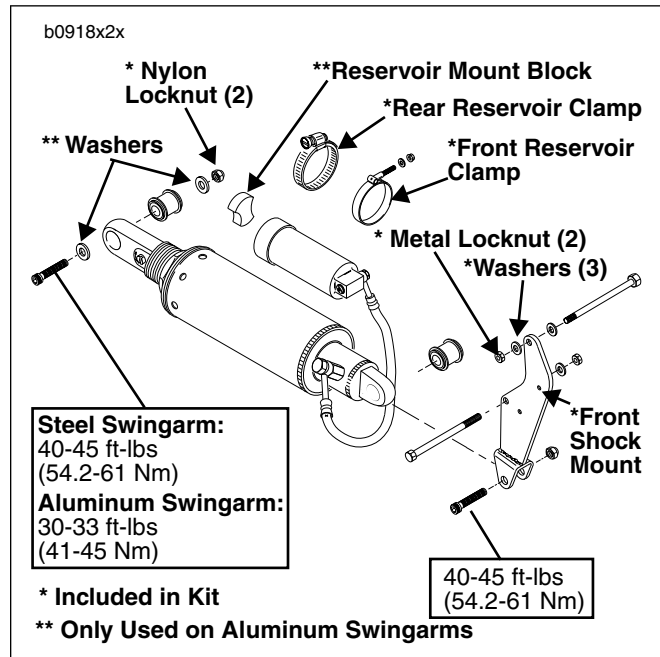

Figure 2. New Shock Absorber Assembly

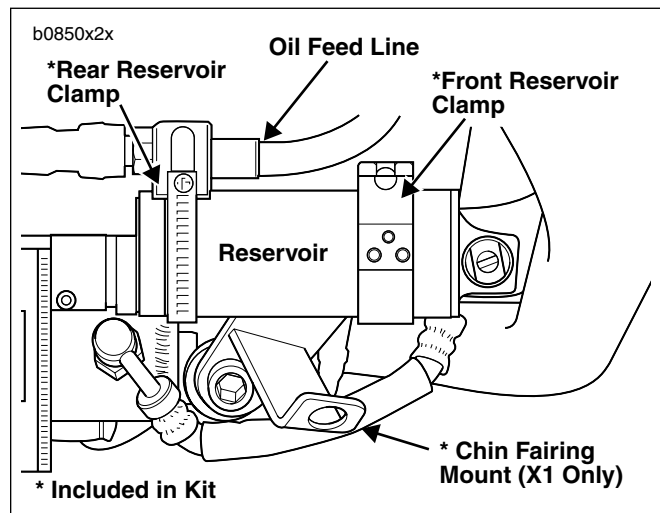

Figure 3. Reservoir Clamps (X1 Model Shown)

3. **All Models Except S1/ S1W/S2/S2T:** Apply LOCTITE THREADLOCKER 243 (Blue) to threads of voltage regulator screws. Install voltage regulator (**new** star washer underneath regulator on 1997 M2, S3/S3T models) to bracket with two screws and washers. Tighten screws to 9-11 ft-lbs (12-15 Nm).

NOTE

All **new** shock absorbers, including those on M2 Models have remote reservoirs that enable rebound damping adjustment.

4. See Figure 2. Position **new** shock absorber from kit in mounting position.
5. Loosely install bolt, washers (aluminum swingarms only) and **new** locknut through rear shock eye and swing arm.
6. **X1 Models Only:** Position new chin fairing bracket in mounting position on front shock eye.
7. Loosely install bolt and **new** locknut through front shock eye and front shock mount and X1 chin fairing bracket (if applicable).
8. **On 1996-1998 vehicles only:** Loosen header tie bar from collector.
9. Position front clamp over reservoir. Loosely install **new** front reservoir clamp to front shock mount (and install **new** header tie bar spacer between front shock mount and header tie bar on 1996-98 vehicles only) with **new** washer and **new** nylon locknut.
10. See Figure 3. Loosely install **new** rear clamp around reservoir and oil feed line.
11. **All Models:** Install **new** reservoir mount block between oil pump fitting and remote reservoir.

NOTE

Torque specification listed in Step 11 are different for aluminum vs. steel swingarms.

12. **1995-1998 Models (steel swingarm):** Tighten front and rear shock mounting hardware to 40-45 ft-lbs (54.2-61.0 Nm).
1999-2000 Models (aluminum swingarm): Tighten front shock mounting hardware to 40-45 ft-lbs (54.2-61.0 Nm). Tighten rear shock mounting hardware to 30-33 ft-lbs (41-45 Nm).
13. Tighten clamps around reservoir. Tighten tie bar to collector (if applicable).
14. **X1 Models Only:** Install chin fairing using **new** wellnut. See Section 2 of X1 Service Manual for procedure.

NOTE:

If installing **new** swing arm from #0816 recall, stop procedure here and see ADJUSTMENT on following page when swing arm installation is complete. If not installing new swing arm, continue with Step 14.

15. Lower and remove jack from under swing arm mount block.
16. Connect negative battery cable. Tighten to 40 **in-lbs** (4.5 Nm).
17. Set preload. See ADJUSTMENT.

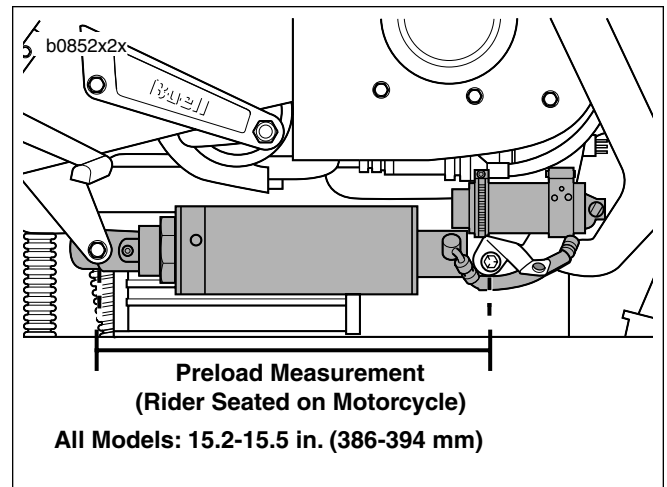

Figure 4. Measuring Preload

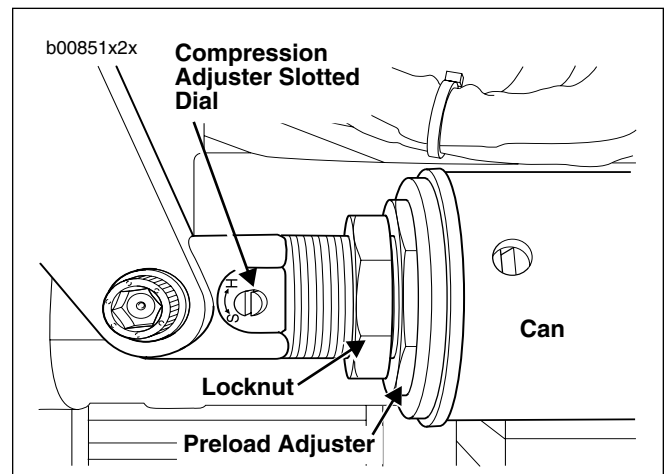

Figure 5. Preload and Compression Damping Adjustment

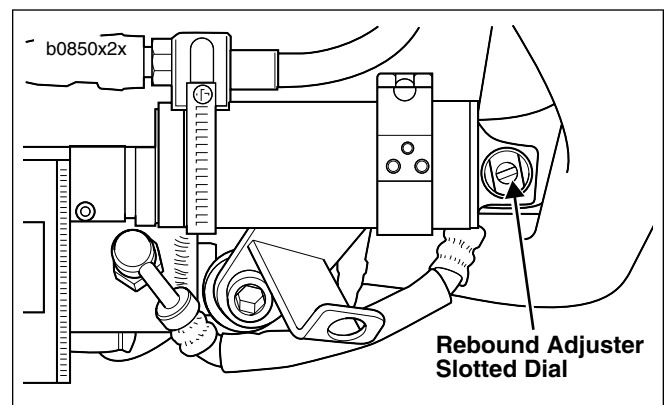

Figure 6. Rebound Adjustment

ADJUSTMENT

1. See Figure 4. Check and adjust rear shock preload.
 - a. With rider seated on motorcycle, the preload is determined by measuring the distance between the centers of the front and rear shock eye and adjusting until the measurement is within specification.
 - b. See below for optimum preload measurements:
 - **All Models:** 15.2-15.5 in. (386-394 mm)
- *Riders with passenger at or near GVWR may exceed optimum preload adjustment.*
2. See Figure 5. To adjust shock preload, loosen the locknut and turn the preload adjuster at the end of the shock to move can towards front or rear of motorcycle. When finished, tighten locknut to 44-58 ft-lbs (59-78 Nm).
 - a. Tighten adjuster (move can towards rear of motorcycle) to **increase** preload.
 - b. Loosen adjuster (move can towards front of motorcycle) to **decrease** preload.

NOTE:

- *All measurements must be taken with rider seated on motorcycle.*

NOTE

- *See Figures 5 and 6. To adjust rear shock to maximum damping setting, use screwdriver to turn slotted dial on appropriate adjuster clockwise until it stops. This is the maximum damping setting.*
- *See Figures 5 and 6. To adjust rear shock to factory recommended settings, turn dial counterclockwise from maximum damping the amounts shown in Steps 3 and 4 to align the reference marks.*

3. See Figure 5. Set compression damping using the slotted dial on the shaft at the rear of the shock. New factory setting is as listed below:
 - **S1/S1W/M2/X1 Models:** full damping minus 2.25 turns.
 - **S2/S2T Models:** full damping minus 2.5 turns.
 - **1997-1998 S3/S3T Models:** full damping minus 2.5 turns.
 - **1999-2000 S3/S3T Models:** full damping minus 2.5 turns.
4. See Figure 6. Set rebound damping using the slotted dial on the remote reservoir at the front of the shock. New factory setting is as listed below:
 - **S1/S1W/M2/X1 Models:** full damping minus 1.5 turns.
 - **S2/S2T Models:** full damping minus 1 turn.
 - **1997-1998 S3/S3T Models:** full damping minus 1 turn.
 - **1999-2000 S3/S3T Models:** full damping minus 1 turn.

NOTE

When preload is increased, both compression and rebound damping should be increased. If preload is decreased, both compression and rebound damping should be decreased.

5. Test ride motorcycle.
6. Provide customer with Customer Instructions for Shock Replacement and Adjustment (Instruction Sheet Number -J01561) provided in kit.